



INTERSTATE-McBEE



**Core Reference Sheet
for Remanufactured Injectors
for Detroit Diesel[®], Cummins[®],
Caterpillar[®] and Navistar[®]**



**4901 Lakeside Avenue
Cleveland, OH 44114-3996
Telephone: 800-321-4234
Telephone: 216-881-0015
Fax: 216-881-0805**

**Website: www.interstate-mcbee.com
e-mail: sales@interstate-mcbee.com**

© Detroit Diesel is a registered trademark of the Detroit Diesel Corporation.
© Caterpillar and CAT are registered trademarks of Caterpillar, Inc.
© CUMMINS is a registered trademarks of Cummins, Inc.
© Heui is a registered trademarks of Caterpillar, Inc.
© Navistar is a registered trademarks of Navistar, Inc.

Rev 7/2013

Prices are subject to change without notice.
*All manufacturer's names, numbers, symbols and descriptions are used for reference purposes only and does not imply that any part listed is the product of these manufacturers.

Detroit Diesel® Injectors



C-NC9 and C-92M

This is a standard Detroit, N, C, 53, 71, 92 Series injector style. Please note that the nut on the NC9 has two smaller grooves.



C-92E

These cores look exactly the same as a C-NC9 core, but an C-NC9 core is not an acceptable return. The differences are internal, so always go by the part number of the injector.

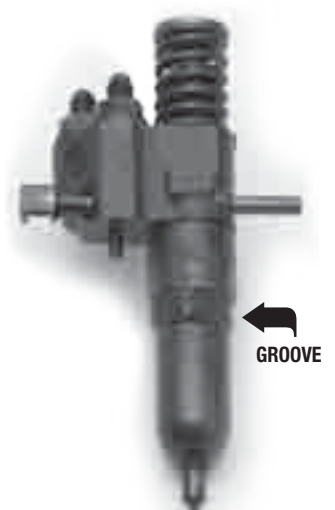

C-71S

This is a Detroit S injector core. Note that the body is similar to the C-NC9 core, but the nut on the S core has one large groove.



C-71H

This is a Detroit HV core. The body is different than an NC9, and the nut has one large groove.



C-82A, C-82B, C-82C

This is a Detroit 8.2L injector core. The 8.2L cores look the same, but the difference can be found by the letter stamped into the body clamp.

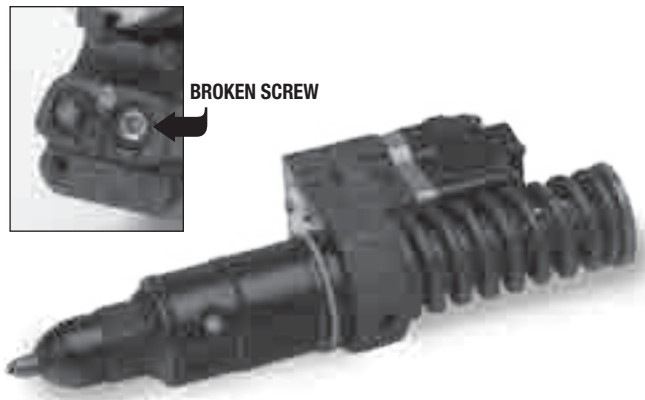

C-S60DDEC2, C-S60DDEC3/4

Each core can be identified by the tower of the body, underneath the spring. The C-S60DDEC2 core has two distinct steps and the C-S60DDEC3/4 has a tapered tower.

Series 60 cores with a broken or missing stator screw will not be accepted.



Cummins® Cores



C-PTD

This is a Cummins standard PTD core. Note that the spring is slightly exposed.



C-30B

This is a Cummins 5/16 PTD core. It is smaller than the standard PTD core with a more exposed spring.



C-41K

This is a Cummins K PTD core. This core is longer than the standard PTD core and the spring is much more exposed.



C-T/S

This is a Cummins standard Top Stop (T/S) core. Notice that the core does not have a visible spring on the top.



C-36B

This is a Cummins L10 T/S injector core. It is very similar to the standard T/S core, but the standard T/S is longer and wider than an L10 T/S. If in doubt, check the part number stamped on the injector.

CUMMINS SELECT CORES

FOR COMPLETE CORE CODE INFORMATION ON CUMMINS SELECT INJECTORS, REFER TO OUR REMANUFACTURED INJECTORS AND FUEL PUMPS PRICE LIST.

CORE RETURNS MUST MEET THE FOLLOWING CRITERIA:

- Units must be properly identified with their part number.
- Units must be returned as off of the engine – assembled and complete.
- Units damaged by fire will not be acceptable.

GROUP CLASSIFICATION OF CORES:

Cores will be accepted for any of the exchange injectors within the specific group classification. Unacceptable cores not meeting the above criteria will be scrapped and no credit will be issued.

SELECT CORES RETURNED WITHOUT INJECTOR PART NUMBERS WILL BE

***INTERSTATE-McBEE REMAN CUMMINS SELECT ACCEPTANCE LIST**
 Please assure cores being returned are from the same group as the rebuilt units you order.

C-CELECT1
3652542

C-CELECT2
3087557
3411752
3411753
3411756
3411758

C-CELECT3
3087560
3411759
3411760
3411761
3411762
3411763
3411764
3411765
3411766
3411767

Caterpillar® Cores



Caterpillar 7000 series core (ORXXXX)

These cores are only exchangeable by part number. For example if an R-OR3418 is purchased we must receive an OR3418 or 8N7005 for exchange.



Caterpillar 7000 series cores with pushed in tips will not be accepted. Bent nozzles will also not be accepted. Any cores received with missing fuel lines will also not be accepted. Previously we could not accept any 7000 nozzle cores with a pushed out tip. Now some of these cores are acceptable but must measure within the specifications listed below.

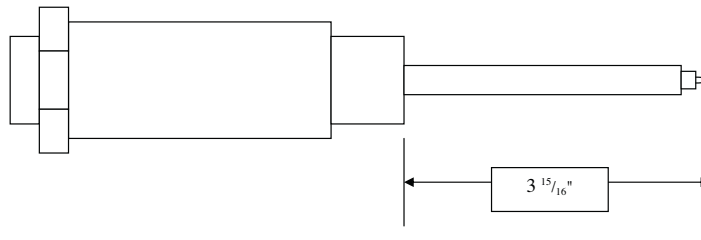

CAT 3126B Electronic Injectors

***INTERSTATE-McBEE REMAN 3126B INJECTOR CORE ACCEPTANCE LIST**
 Please assure cores being returned are from the same group as the rebuilt units you order.

C-3126BTYP1	C-3126BTYP2	
1459360	1260499	1964229
1551819	1317150	1977107
1731012	1417837	1986605
1734566	1731013	1996065
1739379	1734059	2051285
1881320	1739267	2225926
2033771	1739268	2225967
2046714	1739272	2225972
2225963	1774754	0R9349
2225965	1780198	0R9350
0R9348	1780199	10R0781
10R1262	1961401	10R0782



This is an example of an OR9349

CORE RETURNS MUST MEET THE FOLLOWING CRITERIA:

- Units must be properly identified with their part number.
- Units must be returned as off of the engine – assembled and complete.
- Units damaged by fire will not be acceptable.

CORES RETURNED WITHOUT INJECTOR PART NUMBERS WILL BE REJECTED.

GROUP CLASSIFICATION OF CORES:

Cores will be accepted for any of the exchange injectors within the specific group classification. Unacceptable cores not meeting the above criteria will be scrapped and no credit will be issued.

CAT Electronic Injectors

***INTERSTATE-McBEE REMAN CAT EUI CORE ACCEPTANCE LIST**

Please assure cores being returned are from the same group as the rebuilt units you order.

C-3406ETYPE1	C-3406ETYPE2	C-3406ETYPE3	C1012C
1026236	1022014	1026230	1372500
1095038	1034562	1171146	1945083
1170481	1095021	1171148	1470373
1187929	1170482	1189035	1602303
1189027	1188010	1523680	2123463
1408951	1189030	1913004	1601090
1592631	1408993	2113024	OR8773
1913002	1592479	2113027	OR8774
2113022	1913003	OR4118	OR8775
OR4332	2113023	OR4668	OR8776
OR4895	OR4119	OR4893	OR8777
OR9256	OR4300	OR9258	OR8778
10R2782	OR4331	10R0958	
10R0956	OR4894	10R2780	
	OR9257		
	10R0957		
	10R2781		
	10R8501		



This is an example of an OR8773

CORE RETURNS MUST MEET THE FOLLOWING CRITERIA:

- Units must be properly identified with their part number.
- Units must be returned as off of the engine – assembled and complete.
- Units damaged by fire will not be acceptable.

CORES RETURNED WITHOUT INJECTOR PART NUMBERS WILL BE REJECTED.

GROUP CLASSIFICATION OF CORES:

Cores will be accepted for any of the exchange injectors within the specific group classification. Unacceptable cores not meeting the above criteria will be scrapped and no credit will be issued.

Navistar HEUI Core Identification and

ONLY INJECTORS WITH THE SAME CORE CODES WILL BE ACCEPTABLE FOR CREDIT

The connector at the top of the injector must be intact. If it is broken or chipped the core is NOT ACCEPTABLE. This injector has an acceptable connector.



On the TOP of the injector, look for the TWO LETTERS at the beginning of the injector part number. These two letters will identify the injector core code. This injector is a "BI".

Reference Numbers							Core Code
181934C1	1819834C1	1823736C94	1824917C2	1824928C94		2593588C91	BA
1824739C1	1824742C91	1824918C2	1824929C94			2593589C91	BB
1824740C1	1824743C91	1824919C2	1824930C94			2593590C91	BC
1824741C2	1824744C94	1824920C2	1824931C94			2593591C91	BD
1824839C94	1829336C1	1829837C2	1829838C94	1829839C93	1829926C2	2593592C91	BE
1830145C91	1830146C92	1830146C93	1830146C94	1830147C2	1830148C2	2593593C91	BF
1830559C91	1830560C2	1830561C92	1830562C2	1830740C92	1830741C92	2593594C91	BI
1830155C91	1830156C91	1830157C1	1830158C1	1830570C91	1830573C2	2593596C91	BG
1830094C92	1830570C92	1830571C2	1830572C92	1830572C93	1830573C2	2593596C91	BJ
1830691C1	1830692C91	1830693C1	1830694C91	1830694C93		2593597C91	BN
1836250C1	1836251C91	1836252C91	1836253C1				NOT ACCEPT



INTERSTATE-McBEE



Core Returns:

Cores must be returned as removed from the engine, assembled and complete. Units damaged by fire or rust will not be accepted. Cores will be accepted for any of the exchange injectors within the specific group or core code classification (reference Remanufactured Injector Price List). All core returns must be sent freight prepaid to 4901 Lakeside Avenue, Cleveland, Ohio 44114, Attn: Core Return Department. A packing list must be included with all core returns. Information such as company name, address, and/or contact person is required. Details such as a list of the core quantity returned, core type, order or invoice numbers are also required. Copies of order packing list or our invoice are acceptable forms of return paperwork. Credit will only be issued for cores owed. The customer will be contacted regarding any discrepancy and given 10 days to respond. Additional cores will either be scrapped or returned at the customer's expense. We will not "bank" any extra cores returned. Any deviation to these instructions will cause delay in processing the core credit.

INTERSTATE-McBEE, LLC

4901 Lakeside Avenue
Cleveland, OH 44114-3996 U.S.A.
Telephone: 800-321-4234
Telephone: 216-881-0015
Fax: 216-881-0805
Website: www.interstate-mcbee.com
e-mail: sales@interstate-mcbee.com